

The Robertshaw® 5500 M series is a voltage sensing (parallel circuit) infinite switch designed to replace the current VSI (INF) switch. The 5500 M series is the replacement control for the current model INF. This patented control has the smallest physical dimensions possible to adapt to common application specifications and maintains the highest level of quality and performance.

The residential model has the exclusive universal design of the square break-off shaft. Included with these kits are the shaft adaptors that allow the service person to use the customer's original dial on the replacement switch. The shaft can be broken off to the required length to adapt to numerous OEM applications.

The commercial model differs only in that it has a heavy-duty dial shaft (requiring no dial shaft adaptors).

### Specifications:

UL Approved #E110428

15 Amps @ 120/240 Volt 50/60 Hz for 200°F (93°C) ambient

13 Amp rating for all temperatures up to maximum ambient of 257°F (125°C)

### Options:

Push-to-Turn or Non-Push-to-Turn

Clockwise or Counterclockwise shaft rotation from OFF

### Key Features:

Controllable range of output power with Lo and Hi detents

Compact and lightweight design

### RESIDENTIAL MODEL

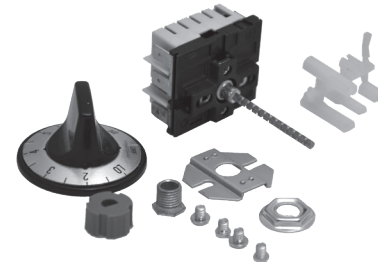

### COMMERCIAL MODEL

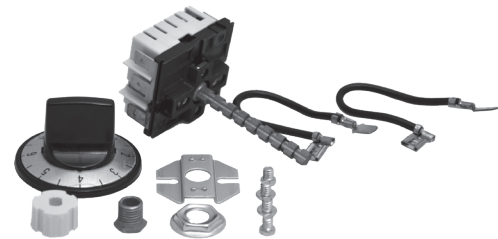

## INSTALLATION INSTRUCTIONS

**CAUTION: This device should be installed by a qualified service technician with due regard for safety, as improper installation could result in a hazardous condition.**

1. Unplug range or disconnect power.
2. Remove dial from switch.
3. Gain access to the inoperative switch. Refer to the original user manual for the appliance for proper disassembly.
4. Label all wires with tags or make an exact drawing of wiring configuration before removing any wires.
5. Remove original switch.
6. Determine mounting type for the new switch: Screw Mount or Palnut.

**Note: The 5500 M must be mounted with the slotted vents at the top.**

Screw mount (Figure 1) is the most common. Attach the new switch to the rear panel with the original screws or using the two flathead screws supplied in the kit.

Palnut mount (Figure 2) requires adding the bushing and the bracket before inserting the shaft through the rear panel. Use the two smaller Phillips head screws to attached bracket vertically or horizontally to the new switch. Secure the switch (finger snug) to the rear panel with the palnut.

7. Temporarily mount the switch and place the original dial on the new switch shaft using one or more of the adaptors on the sprue tree (Figure 3). Make sure the shaft goes in all the way. See Figure 4 for assembly of spring clip to adaptor if applicable.

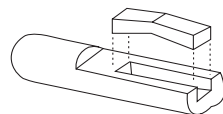

Figure 4

8. Measure distance from back of dial to the front of the panel and subtract an 1/8". This becomes your measurement needed in the next step.
9. Remove the switch. Use the measurement from previous step and measuring from the end of the shaft mark the shaft at the nearest break-off point (or at the next break-off groove toward the end of the shaft to avoid breaking off too short).

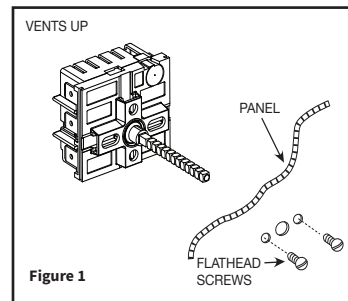

Figure 1

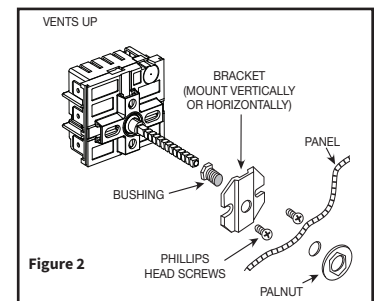

Figure 2

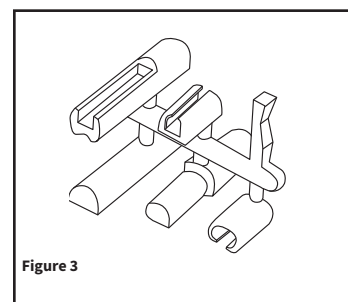

Figure 3

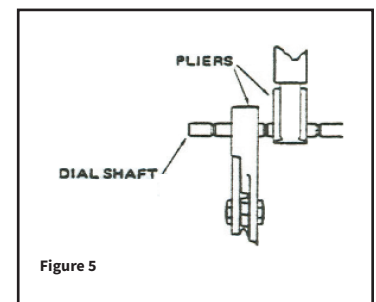

Figure 5

**Note: If the control is push-to-turn and the shaft is broken off too short it will not allow the dial to detent as needed for proper operation. The control will need to be replaced as replacement shafts are not available.**

10. To break off the shaft: Use two (2) pairs of pliers – one on each side of the marked groove (Figure 5). Hold pliers firmly and break shaft. DO NOT HOLD SWITCH BODY.
11. Remount switch, then proceed to wiring instructions.

## WIRING ROBERTSHAW VSI TO ROBERTSHAW 5500 M SERIES

Connect wires from old switch to new switch as follows:

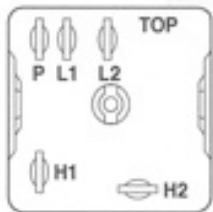

### VSI Switch Terminal #

L1 connect to  
L2 connect to  
P connect to  
H1 connect to  
H2 connect to

### 5500M (MPS) Switch Terminal #

L1  
L2  
P  
H1  
HC

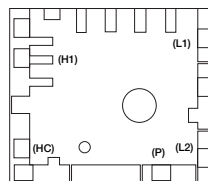

## WIRING EGO TO ROBERTSHAW

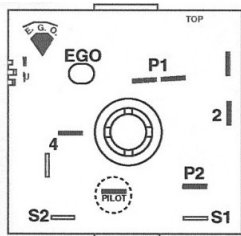

### Old (EGO) Switch Terminal #

P1 connect to  
P2 connect to  
Pilot connect to  
4 connect to  
2 connect to

### 5500 M (MPS) Switch Terminal #

L2  
L1  
P  
H1  
HC

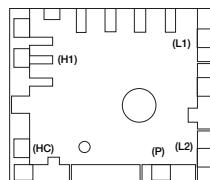

## SLIP-FIT® DIAL ASSEMBLY

**NOTE: IT IS ESSENTIAL TO READ EACH STEP COMPLETELY BEFORE PERFORMING THE DIRECTIONS GIVEN IN THAT STEP.**

1. Turn control to the "Off" position.
2. Locate the 4-way insert included with this dial kit. Push the 4-way insert flush onto the tip of the dial shaft of the control.
3. Referring to the other control knobs on the appliance, determine which way the new knob is to be oriented in the "Off" position; vertical or horizontal.
4. Using the vertical or horizontal orientation desired, partially assemble the knob onto the insert to obtain proper alignment. Then remove the knob with the insert attached, and press the insert all the way onto the knob.

When completely in place, approximately 1/8" of the 4-way insert will be outside of the knob. Reinstall knob.

5. Take the Slip-Fit overlay, and carefully remove the clear protective covering over the numbered side. Begin removal from the inside edge of the overlay.
6. Carefully peel off the backing from the adhesive that is on the back of the Slip-Fit overlay. Try not to touch the adhesive.
7. Position the Slip-Fit dial overlay over the knob with the "Off" position aligned in the desired position. Carefully slide the Slip-Fit overlay down and over, locating the ribs on the knob.
8. Press the Slip-Fit overlay firmly into position. Use a soft cloth and rub around the overlay to obtain a permanent fit.

## MOUNTING DIMENSIONS

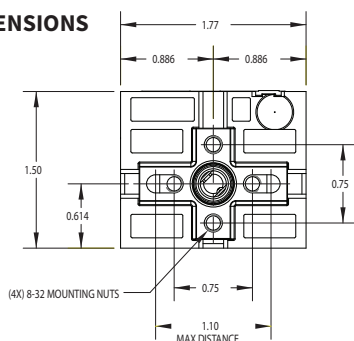

## WIRING SCHEMATIC

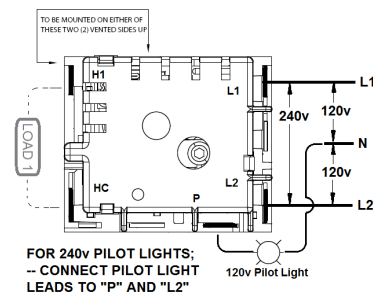

**WARNING: The rear housing has a 1/4" diameter hole which is an access point to be used ONLY by qualified personnel for insuring proper assembly and calibration of the switch. Any tampering with internal components or altering factory settings of this switch will possibly damage other electrical components on the appliance and will immediately VOID the WARRANTY of the switch.**

## ORDERING INFORMATION

5500M Series		Replaces		VOLTAGE	MODEL
ROBERTSHAW PART #	ROBERTSHAW FACTORY #	ROBERTSHAW PART #	FACTORY #		
5500-103M	MPS-V112-1-UXM	5500-103	INF-120-599	120V AC	RESIDENTIAL
5500-104M	MPS-V112-1-UXM	5500-104	INF-120-599	120V AC	RESIDENTIAL
5500-113M	MPS-V113-1-UXM	5500-113	INF-120-599B	120V AC	RESIDENTIAL
5500-203M	MPS-V116-UXM	5500-203	INF-240-597	240V AC	RESIDENTIAL
5500-204M	MPS-V116-UXM	5500-204	INF-240-597	240V AC	RESIDENTIAL
5500-208M	MPS-V115-2-UXM	5500-208	INF-208-642	208V AC	RESIDENTIAL
5500-213M	MPS-V117-UXM	5500-213	INF-240-597B	240V AC	RESIDENTIAL
5500-134M	MPS-V114-1-UNM	5500-134	INF-120-1152	120V AC	COMMERCIAL
5500-135M	MPS-V114-1-UNM	5500-135	INF-120-1152	120V AC	COMMERCIAL
5500-234M	MPS-V119-UNM	5500-234	INF-240-1153	240V AC	COMMERCIAL
5500-235M	MPS-V119-UNM	5500-235	INF-240-1153	240V AC	COMMERCIAL

**Robertshaw**  
RANCO • PARAGON • CASTFUTURA

Customer Service  
+1 800 304 6563  
HVACCustomerService@robertshaw.com

Technical Service  
+1 800 445 8299  
TechnicalService@robertshaw.com

www.robertshaw.com  
©2025 Robertshaw  
04/25- 354-00028-003 Rev E