



INSTALLATION DATA

SERIES 35-63

4 VAC MICROPROCESSOR-BASED INTERMITTENT PILOT IGNITION CONTROL

PRODUCT DESCRIPTION

The 35-63 is a 24 VAC intermittent pilot (spark-to-pilot) ignition control. The control uses a microprocessor circuit to provide precise, repeatable timing and operating sequences. On-board diagnostics with LED output makes troubleshooting easy and ensures safe and efficient operation.

APPLICATIONS

- Commercial cooking
- Gas furnaces
- Unit heaters
- Water heaters
- Other applications requiring intermittent pilot

FEATURES

- Safe start with DETECT-A-FLAME® flame sensing technology
- Custom pre-purge and inter-purge timings*
- Single or three trials for ignition
- Mounts on standard 4-in. junction box
- System diagnostic LED
- Flame current test points
- Local or remote flame sensing
- Automatic reset option**

SPECIFICATIONS

Input Power	Control: 18-30 VAC 50/60Hz (Class 2 Transformer)
Input Current	300 mA @24 VAC with main and pilot gas valve relays energized (control only)
Main Gas Valve	2.0A max (continuous)
Pilot Gas Valve	2.0A max (continuous)
Operating Temperature	-40°F to +176°F (-40°C to +80°C)
Storage Temperature	-40°F to +185°F (-40°C to +85°C)
Flame Sensitivity	0.7 µA minimum
Flame Failure Response	0.8 seconds maximum
Flame Detector Self-check Rate	Once per second minimum
Gas Types	Natural, LP, or manufactured
Spark Rate: Remote Local	50/60 sparks/sec 25/30 sparks/sec
Size (LxWxH) with enclosure	5.69 x 3.94 x 1.87 inches (14.45 x 10.01 x 4.75 cm)
Moisture Resistance	Conformal coated to operate non-condensing to 95% R.H. Module should not be exposed to water
Ingress Protection	Not rated, protection provided by appliance in which it is installed
Tries for Ignition	One or three try versions available
Trial for Ignition Periods	15, 30, 60, 90 seconds available
Pre-purge and Inter-purge Timings	0, 15, 30, 45 seconds or 4 minutes available



EXPORT INFORMATION (USA)

Jurisdiction: EAR
ECCN: EAR99

AGENCY CERTIFICATIONS

	Recognized under the UL component program, UL 372. Software certified to ANSI/UL 1998. UL File MH8817
	Design certified to ANSI Z21.20, CAN/CSA C22.2 No. 199-M89
	CE Approved to EN 298:2012
	Code Compliant to: AS 4625 - 2008 AS 4622 - 2004

- * Pre-purge time cannot exceed inter-purge time on CE Approved models.
- ** Automatic reset is not allowed for CE Approved models.
- *** EMC emission requirements shall be verified after incorporation of the burner control system into the end use appliance.

SEQUENCE OF OPERATION / FLAME RECOVERY / SAFETY LOCKOUT

START UP - HEAT MODE

When a call for heat is received from the thermostat supplying 24 VAC to TH/W, the control will reset, perform a self-check routine, flash the diagnostic LED and begin a pre-purge delay. Following the pre-purge period, the pilot gas valve is energized and sparking commences for the Trial For Ignition (TFI) period. The main gas valve remains de-energized until the pilot flame is detected.

When the pilot flame is detected during TFI, the sparking process is terminated and the main gas valve is energized. The thermostat and pilot burner flame are constantly monitored to assure proper system operation. When the thermostat is satisfied and the demand for heat ends, the pilot and main valves are immediately de-energized.

FAILURE TO LIGHT - LOCKOUT

Single Trial Model

Should the pilot burner fail to light or the pilot flame is not detected during the TFI period, the pilot valve will de-energize and the control will go into lockout. The LED will indicate the fault code for ignition lockout.

Multi Trial Model

Should the pilot burner fail to light or the pilot flame is not detected during the first TFI period, the pilot valve will de-energize. The control then goes through an inter-purge delay before an additional ignition attempt. The control attempts two additional ignition trials before de-energizing the pilot valve and entering lockout. The LED will indicate the fault code for ignition lockout.

Flame Failure-Re-Ignition Mode

If the established pilot flame signal is lost while the burner is operating, the control will respond within 0.8 seconds by de-energizing the main gas valve and energizing the H.V. spark for the TFI period in an attempt to relight the pilot burner. If the pilot burner does not light within the TFI, the pilot gas valve will immediately de-energize and single try models will enter lockout. On multi-try models, a new TFI sequence will begin after an inter-purge delay. Multi-try models perform two additional attempts to light the burner before de-energizing the gas valves and entering lockout. If the pilot burner relights, normal operation resumes.

Flame Failure-Recycle Mode





With the "Recycle after Loss of Flame" option, upon loss of pilot flame, the pilot and main gas valves are de-energized and the control proceeds to inter-purge before attempting to relight the pilot flame. Multi-try models permit three tries for ignition including inter-purges. If the pilot burner relights, normal operation resumes. If the pilot burner does not relight, the control will enter lockout.

Lockout Recovery

Recovery from lockout requires a manual reset by either resetting the thermostat, or removing 24 VAC for a period of 5 seconds. On models with automatic reset, if the thermostat is still calling for heat after one hour, then the control will automatically reset and attempt to ignite the burner.

MOUNTING AND WIRING

The Series 35-63 is not position-sensitive and can be mounted vertically or horizontally. The case may be mounted on any surface with #6 sheet metal screws. The control also supports direct mounting to a standard NEC 4-in. junction box.

 CAUTION	All wiring must be performed in accordance with both local and national electrical codes.
 CAUTION	Label all wires prior to disconnection when servicing controls. Wiring errors may cause improper and dangerous operation. A functional checkout of a replacement control should always be performed.
 WARNING	This product uses voltages of shock hazard potential. Wiring and initial operation must be performed by a qualified service technician.
 WARNING	Operation outside specifications could result in failure of the Fenwal product and other equipment with potential for injury to people and property.

Terminal Designations		
Terminal	Description	Quick Connect (inch)
TH/W	Thermostat Input	1/4"
PV1	Pilot Valve Power	3/16"
MV1	Main Valve Power	1/4"
V2	Valve Ground	3/16"
GND	System Ground	3/16"
S1	Remote Flame Sensor (Optional)	3/16"
H.V.	High Voltage Output	1/4"
FC+, FC-	Flame Current Test Points	Varies by model

MOUNTING AND WIRING

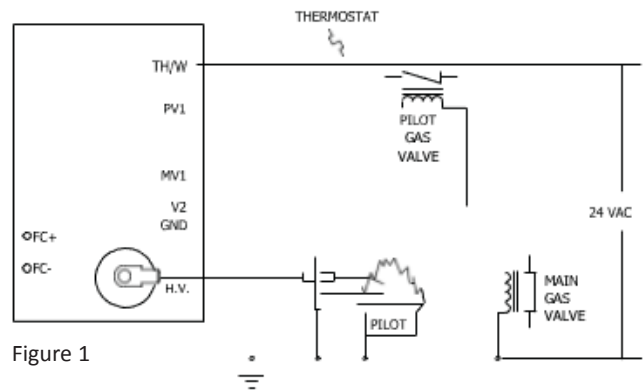

Figure 1

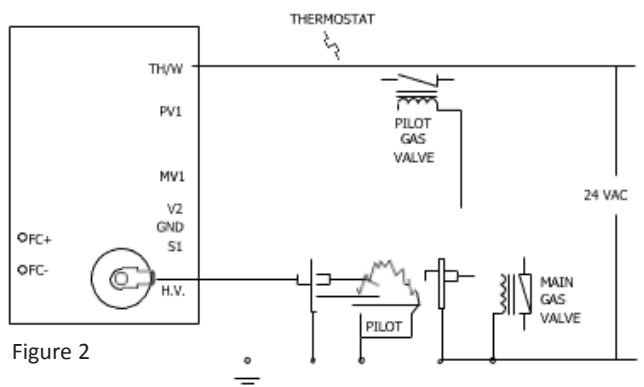

Figure 2

HIGH VOLTAGE AND REMOTE SENSE CABLE REQUIREMENTS

The HV Ignition Cable must meet a voltage rating of 25 KV and an insulation rating of 200 °C. Recommend length of 3ft (.9m) or less. Consult factory for longer lengths.

Remote flame sense cable must meet a voltage rating of 250V and an insulation rating of 200 °C. Recommended length of 10ft (3m) or less. Consult Factory for longer lengths.

TROUBLESHOOTING

Troubleshooting Guide	
Symptom	Recommended Actions
1. Control does not start	A. Miswired B. 24 VAC transformer fault C. Fuse circuit breaker fault D. Faulty control, check LED for fault codes
2. Thermostat on - no spark	A. Miswired B. Faulty thermostat, no voltage at thermostat terminal TH/W C. Faulty control, check LED for fault codes
3. Valve on - no spark during TFI	A. Shorted electrode - establish 1/8-inch gap B. Check high voltage cable C. Miswired
4. Spark on - valve off	A. Valve coil open B. Valve wire disconnected C. Faulty control, check voltage at gas valve terminals PV1 or MV1 and V2
5. Flame okay during TFI - no flame sense after TFI	A. Check electrode position B. Check high voltage wire C. Poor ground at burner D. Poor flame, check flame current

Fault Conditions	
Fault Conditions	Fault Mode
Steady On	Internal Control Failure
2 Flashes	Pilot flame without call for heat
3 Flashes	Ignition Lockout

Note: During a fault condition, the LED will flash on for 1/4 second and off for 1/4 second as needed to indicate the fault code. The code will repeat every 3 seconds. Removing power from the control will clear the fault code.

INTERNAL CONTROL FAILURE

If the control detects a software or hardware error, all outputs are turned off and the LED displays a Steady On condition. If this condition persists after an attempt to restart, then the control must be replaced.

PROPER ELECTRODE LOCATION

Proper location of electrode assembly is important for optimum system performance. The electrode assembly should be located so that the tips are inside the flame envelope and about 1/2-inch (1.2 cm) above the base of the flame as shown:

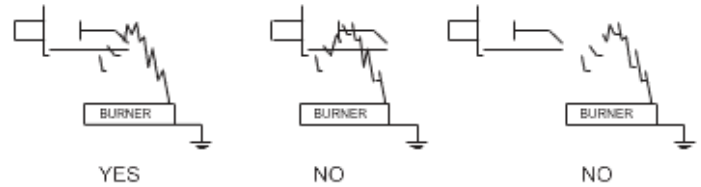

- Note:**
- Ceramic insulators must not be in or close to the flame.
 - Electrode assemblies must not be adjusted or disassembled. Electrodes are NOT field adjustable.
 - Electrodes should have a gap spacing of 0.125 ± 0.031 in (3.12 ± 0.81 mm), unless otherwise specified by the appliance manufacturer. If spacing is not correct, the assembly must be replaced.
 - Exceeding temperature limits can cause nuisance lockouts and premature electrode failure.
 - Electrodes must be located where they are not exposed during normal operation.

FLAME CURRENT MEASUREMENT

Flame current is the current that passes through the flame from sensor to ground. To measure flame current, connect a True RMS or analog DC micro-ammeter to the FC+ and FC- terminals. Readings should be 1.0 μ A DC or higher. If the meter reads negative or below "0" on scale, meter leads are reversed. Re- connect leads with proper polarity.

Alternately, a Digital Voltmeter may be used to measure DC voltage between FC+ and FC- terminals. Each micro-amp of flame current produces 1.0 VDC. For example, 2.6 VDC equates to 2.6 μ A.

A good burner ground that matches the control ground is critical for reliable flame sensing.

DIMENSIONS

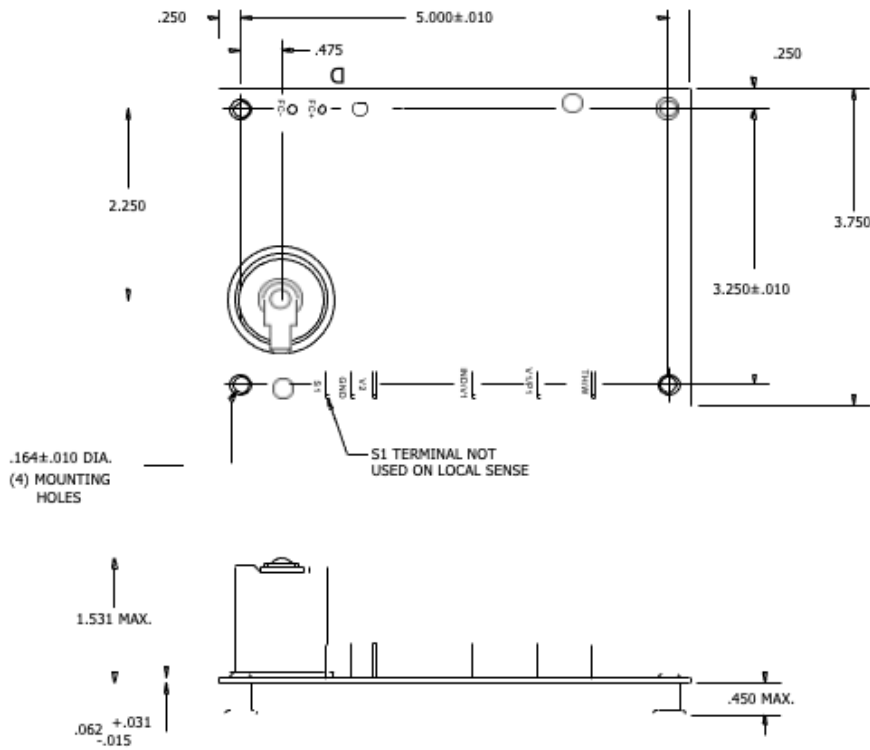

Figure 3 Uncovered with Standoffs

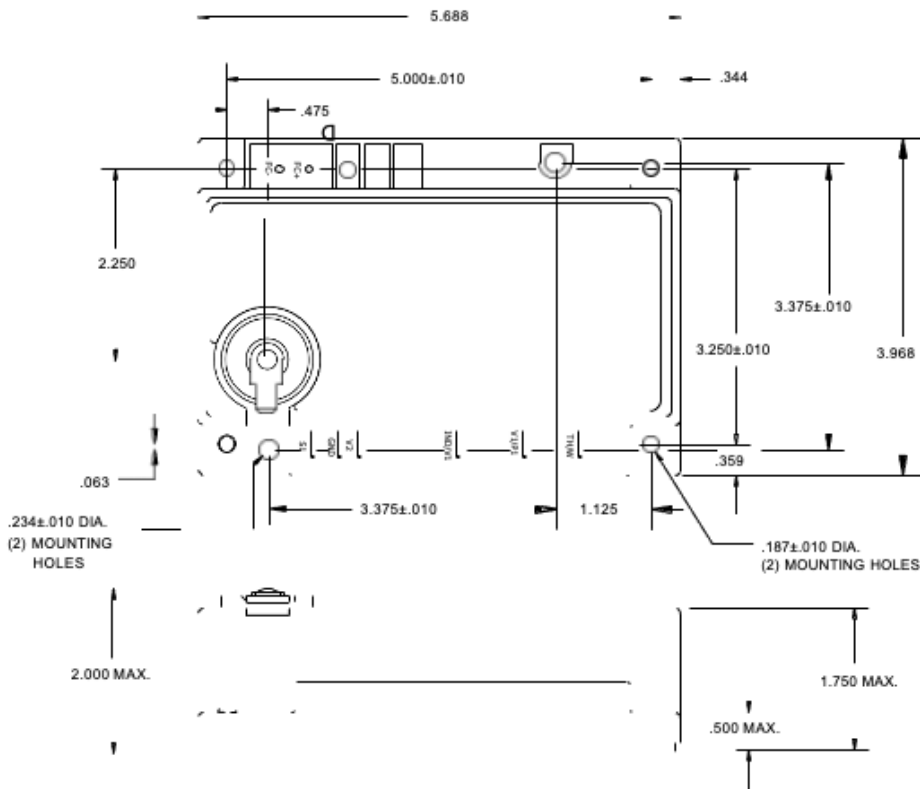

Figure 4 Standard Enclosure

Note: All dimensions are in inches.

PART NUMBER CONFIGURATION

SERIES 35 - 63 0XXX - XXX

PRODUCT

DESIGNATION

- 1 = Recycle After Loss of Flame
- 2 = Standard CE Approved Model*
- 3 = Special CE Approved Model*
- 5 = Re-ignition After Loss of Flame
- 9 = Special Configuration

3 or 9 in this location
i.e. 35-63 0[901]-113)

Indicates a special configuration.

XX is a sequentially assigned part number and does not follow the standard part numbering configuration.

Consult Fenwal for operating characteristics of this control.

* On CE Approved models, pre-purge time cannot exceed enter-purge time and automatic reset is not permitted.

TRIAL FOR IGNITION TIME

- 1 = 15 Seconds
- 3 = 30 Seconds
- 5 = 60 Seconds
- 7 = 90 Seconds

INTER-PURGE TIME

- 0 = None (Single Try Models Only) 1 = 15 Seconds
- 2 = 30 Seconds
- 3 = 45 Seconds
- 4 = 4 Minutes

PRE-PURGE TIME

- 0 = None
- 1 = 15 Seconds
- 2 = 30 Seconds
- 3 = 45 Seconds
- 4 = 4 Minutes

NUMBER OF IGNITION TRIALS, FLAME SENSE METHOD AND LOCKOUT RESET METHOD

- | | |
|-------------------------------|------------------------------|
| 0 = Single Try, Local Sense | Thermostat/power off reset |
| 1 = Single Try, Remote Sense | Thermostat/power off reset |
| 2 = Single Try, Local Sense | 1 Hour Automatic reset |
| 3 = Single Try, Remote Sense | 1 Hour Automatic reset |
| 5 = Three Tries, Local Sense | Thermostat/power off reset |
| 6 = Three Tries, Remote Sense | Thermostat power off reset 1 |
| 7 = Three Tries, Local Sense | Hour Automatic reset |
| 8 = Three Tries, Remote Sense | 1 Hour Automatic reset |

ENCLOSURE CONFIGURATIONS

- 0 = Noryl Gray Enclosure
- 1 = Integral Standoffs
- 2 = Board Only



Customer Service Telephone 1.800.304.6563
Customer Service Facsimile 1.800.426.0804
HVACCustomerService@robertshaw.com

For Technical Service
Telephone 1.800.445.8299
TechnicalService@robertshaw.com

Robertshaw®, Ranco®, Paragon® and Uni-Line® are trademarks of Robertshaw its subsidiaries and/or affiliated companies. All other brands mentioned may be the trademarks of their respective owners.

www.robertshaw.com
©2021 Robertshaw
06/21 – 352-00314-001