



CAUTION

THIS KIT IS INTENDED FOR USE BY QUALIFIED SERVICE PERSONNEL ONLY. IMPROPER INSTALLATION OF THE NEW CONTROL CAN PRESENT ELECTRICAL SHOCK, SERIOUS PERSONAL INJURY OR FIRE HAZARDS.

Do not attempt disassembly of the oven control.

Be sure all terminals at the rear of new oven control are at a safe distance from covers and panels. Insulate and protect all wiring as necessary.

Before disconnecting and removing the old oven control from the appliance, identify and mark the wiring so it can be correctly reconnected to the new control.

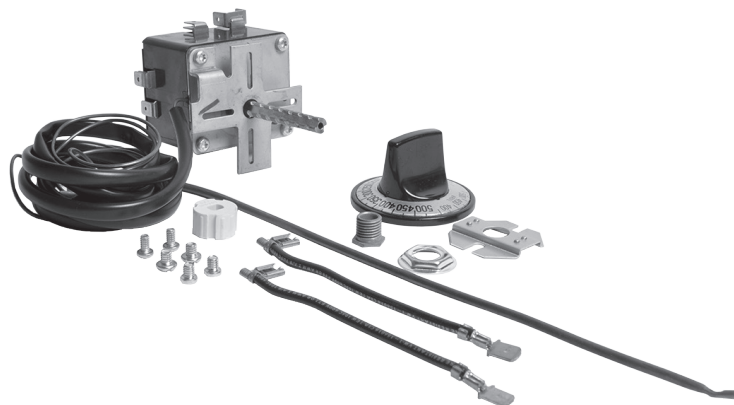

Kit Features

This kit is designed to accommodate most installation configurations. The capillary is 152.5cm (60.0") long plus the 28cm (11.0") bulb sensor, and the control has a 4.5cm (1-3/4") break-off shaft. AUTOMATIC PRE-HEAT, VARIABLE BROIL and SIGNAL LIGHT circuits are on all models. The shafts of all models turn clockwise to increase the oven temperature, and certain kits also contain a four-way knob.

Installation Instructions

1. Determine the correct shaft length by measuring from the front mounting plates of the old and new oven controls. (For bush and nut mounting applications, measure from the bush mounting bracket on the new control and the mounting plate on the old control). Measure the amount (if any) that the new shaft needs to be shortened. If this length falls between two break-off grooves, mark the groove providing the longer length. **NOTE:** (If the original knob is to be replaced). Before cutting the new shaft; check the depth of the cavity where the shaft enters into the new knob. Any variation can be compensated for by lengthening (or shortening) the new shaft.
2. Position a suitable pair of pliers at either side of the marked groove. Hold the pliers very firmly at the control body side of the groove. With the other pair of pliers, carefully snap off the excess amount of shaft. (See Figure 2) **CAUTION:** DO NOT HOLD, OR PLACE ANY STRAIN ON THE BODY OF THE CONTROL.
3. Place and snap the knob clip spring into the wide flat channel of the shaft. The straight end of the knob clip spring must point towards the knob end of the shaft. (See Figure 3)
4. Determine the appropriate mounting method and install the new HARPCO 6700 series control (as indicated in 4a or 4b following). The new control may be installed in any position (3, 6, 9 or 12 o'clock) that will provide the required shaft alignment for the knob OFF position. (See Figure 4)

Bushing Mounting

4. a) Place the bushing over the oven control shaft. Attach the bracket to the oven control using the 2 screws provided. Install the new oven control. Make sure that the control shaft is properly oriented to align with the OFF position on the appliance's control panel. Use the palnut provided to secure the oven control to the control panel.

Screw Mounting

4. b) Place the new oven control into position. Make sure that the control shaft is properly oriented to align with the OFF position on the appliance's control panel. Use the 2 screws provided to attach the oven control onto the control panel.

Oven Control Knob

5. Included with your kit is an electric thermostat knob replacement kit. The only insert you will need from this kit is the yellow insert. Place the yellow insert onto the control shaft. Install the knob onto the yellow insert and rotate the knob counterclockwise to the OFF position. Remove the adhesive backing from the inlay depicted in Figure 1. Place the inlay over the knob so the OFF aligns with the corresponding mark on the control panel.



Figure 1

Capillary Tube

6. Carefully route the capillary tube through to its original location inside of the oven. Locate the capillary bulb into the original retaining clips inside the oven. Make sure that the bulb does not touch any oven surface. Be careful not to kink the capillary line as this will affect the proper operation of the oven control. Coil any excess capillary line outside of the oven and away from all electrical components and terminals.

Replacing HARPER Oven Controls

7. If you are replacing a HARPER oven control, reconnect the wiring to the same numbered terminals on the new oven control. On some double-pole (6711 - 6715) oven controls, L1 and L2 may be found to be reversed from the 6700 series kits. This will not present any difficulty, as the line polarity for the oven circuit is not critical in this application.



INSTALLATION DATA

6700 SERIES

REPLACEMENT OVEN CONTROL KITS

Replacing Other Oven Controls

8. To replace other oven controls, refer to the CROSS REFERENCE and WIRING DIAGRAMS.

Variable Broil

9. The 6700 kit oven controls feature a VARIABLE BROIL option to broil at full heat or a user selected lower heat. To use this feature, turn the knob to BROIL, and then back to the desired temperature. After the variable broil has been used, the knob **MUST** be turned to the OFF position to turn the broil element off.

Calibration

10. The oven control has been carefully calibrated at the time of manufacture and is accurate. However, if re-adjustment should ever become necessary, use the following procedure:

Place the end of a thermocouple (connected to a suitable temperature meter of known accuracy) into the geometric center of the oven cavity. Set the oven temperature to 350°F (175°C) and turn the oven on.

- Allow the oven to cycle OFF and ON at least three times. **DO NOT OPEN THE OVEN DOOR DURING TEST.**
- **AFTER THE FIRST THREE CYCLES**, commence making a note of the OFF - ON temperature readings, AND the total number of OFF - ON cycles. To obtain the actual oven temperature:

EXAMPLE: OVEN SET AT 350°F (AFTER THE FIRST 3 CYCLES)							
Method 1st + 2nd + 3rd = Total Divide by 3, Divide by 2							
Cycles	1st	2nd	3rd	Total	By 3	Result	OVEN TEMP 352
OFF	390	375	370	1135	378	705	
ON	315	330	335	980	327	(378,327)	

- If the average oven temperature varies by more than 25°F either side of the set temperature, calibration is necessary. (In the case of 350°F the allowable temperature tolerance would be 325°F - 375°F).
- To adjust the oven control: Insert a suitable (slotted) screwdriver into the center of the control shaft. Rotating the adjusting screw 20° will change the oven temperature by approximately 10°F. Do not allow the shaft to turn while making the adjustment. Turn the adjusting screw counterclockwise to increase, and clockwise to decrease the oven temperature.

Stem Configurations



Wiring Diagrams

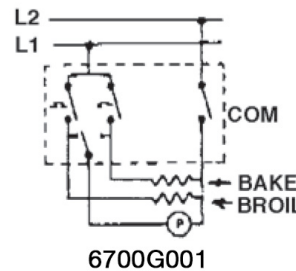

Cross Reference

Kit No.	Stem Configuration	Knob Included	Replaces
6700S0011	A	Yes	Most Harper 6702-6715 controls; many Hart 276 controls; Ranco N-1 and N-3 controls; Robertshaw RA, RB, RC, RD, OP controls and Uni-Line 5430-175, 5440-175/6/7, 5446-275/6

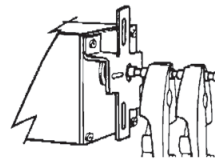

Figure 2

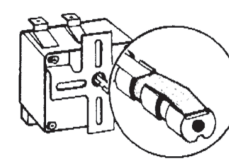

Figure 3

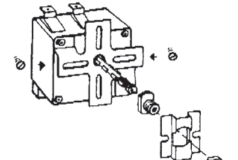

Figure 4

To Bake

Turn oven control knob just to desired temperature. Both Broil (Top) and Bake (Bottom) elements will come on for fast pre-heat. Broil element will turn off automatically when temperature is reached.

CAUTION: If oven door is left open for a long time, broil element may come on again.

To Broil

Turn oven control knob until it clicks into BROIL setting. For maximum broil heat, leave at BROIL. For slower broiling, turn knob back (counterclockwise) to desired setting. Leave oven door open (at broil stop position) for all broiling operations.

NOTE: Before oven can be used for baking, control knob **MUST** be turned to OFF to turn off Broil element.