

### APPLICATION

The Ranco® thermistor sensor is used with the ETC family of electronic temperature controls and supports a temperature range of -30°F to 220°F.

The sensor can be used for air, duct or spot sensing. It can also be used in bulb wells for immersion applications. Multiple sensors can be wired in a series/parallel arrangement for sensing average temperature. For each number of sensors wired in series, an equal number must be wired in parallel. (Wiring diagram for averaging is shown in Figure 5.)

The sensor is designed for use ONLY with Ranco Type ETC temperature regulating controls. Where a control or sensor failure could result in personal injury and/or loss of property, it is the responsibility of the installer to add devices (safety, limit controls) or systems (alarm, supervisory systems) that protect against, or warn of failure.

### SPECIFICATIONS

The sensor is a negative temperature coefficient (NTC) thermistor sensor. The sensor resistance decreases with temperature increase. It is .25" x 1.94" long with 8 ft. #22 AWG cable. The thermistor has a reference resistance of 30,000 ohms at 77°F (25°C).

### SENSOR MOUNTING

For space sensing, mount the sensor where it will be unaffected by heat/cool discharge or radiated heat sources. Spot sensing requires the sensor to be in good contact with the surface being sensed. The sensor can be inserted in a bulb well for immersion sensing.

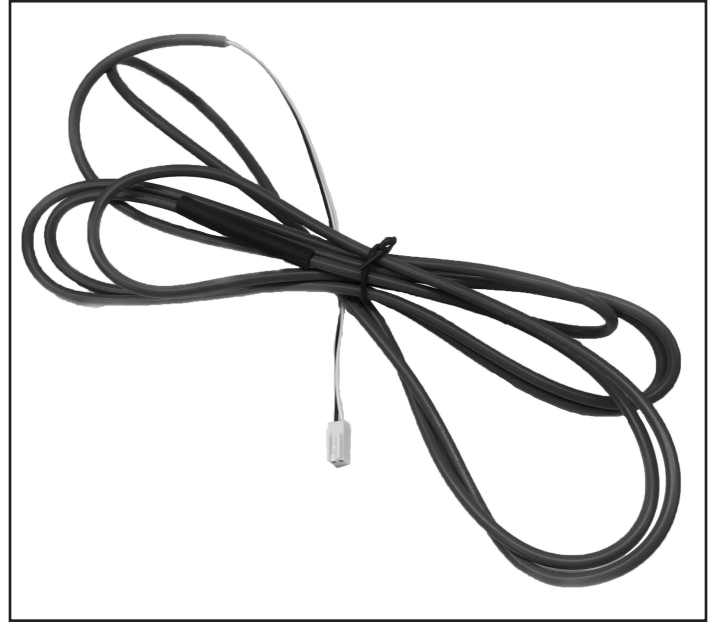

Figure 1  
Temperature Sensor

## IMPORTANT

The schematic drawings and other information included in these instructions are for the purpose of illustration and general reference only. Robertshaw assumes no responsibility for any unconventional application of its control, unless such application has been approved in writing by Robertshaw.

Deg.C.	Deg F.	RES Nom.
-40	-40.0	976187
-30	-22.0	517194
-20	-4.0	285095
-10	14.0	163500
0	32.0	96873
10	50.0	59342
20	68.0	37433
25	77.0	30000
30	86.0	24123
40	104.0	15869
50	122.0	10690
60	140.0	7367
70	158.0	5161
80	176.0	3686
90	194.0	2683
100	212.0	1982
110	230.0	1487

Figure 2

Resistance vs. Temperature Sensor including 8 ft. cable.

## SENSOR REPLACEMENT

ETC models are available with 2 optional Quick Connect Sensor feature that allows for easy sensor replacement due to damage or wear. (Optional Connect Sensor feature is shown in Figure 3)

A damaged sensor can also be replaced by splicing a new Ranco sensor to the cable on ETC models that do not utilize the Quick Connect feature. The sensor is not polarity sensitive.

**CAUTION:** Sensor wiring splices must be made external from the control on models that do not utilize the Quick Connect feature. **DO NOT** attempt to unsolder the sensor at the control board.

To access the sensor connector, disconnect the power supply and open the control. Remove single screw located in the center of the Display Upper Circuit Board and carefully remove Display Board Circuit.

Remove Sensor Strain Relief to allow sensor to be removed from unit.

See Figure 4 for location of sensor strain relief.

The sensor connection is made at the P1 Connector on the Display Upper Circuit Board. See Figure 4 for connection information.

**CAUTION:** Disconnect power to control before wiring to avoid possible electrical shock or damage to the controller.

Additional cable can be spliced to the sensor cable to increase the length beyond the standard 8 feet. It can be extended up to 400 feet. The cable should be at least 22 AWG or larger to keep additional resistance to a minimum.

All splices and wire lengths added to the sensor cable should be made according to acceptable wiring practices and should conform to the National Electrical Code and local regulations. Use copper conductors only. Shielded cable is not required.

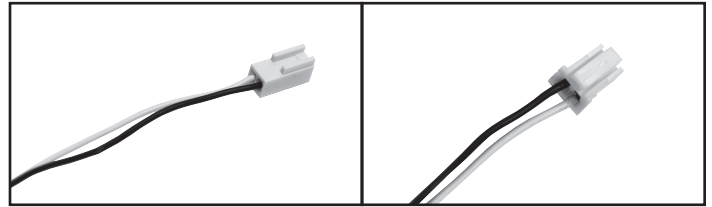

Figure 3

Optional Connect Sensor

**Replacement Sensor - Order  
Uni-Line Number 1309007-044  
(OEM Number 1309007-048)**

**CHECKOUT PROCEDURE**

1. Before applying power, make sure installation and wiring connections are correct.
2. Apply power to the control and observe one or more cycles of operation.
3. If performance indicates a problem, check sensor resistance to determine if sensor or controls at fault.
4. To check sensor resistance, disconnect sensor and measure the resistance across the leads while measuring temperature at the sensor.
5. Allow thermometer to stabilize before taking a reading. Several minutes may be required for the sensor to acclimate to the temperature being sensed. Body heat can affect the sensor.
6. Compare reading using the Resistance vs. Temperature chart in Figure 2. The reading may not agree exactly. This can be due to the accuracy of the thermometer used, sensor tolerances, handling of the sensor, and the sensor's time constant.

**FIELD REPAIRS**

Field calibrating or repairs to the ETC control must not be attempted. Sensors and replacement controls are available through Ranco wholesalers.

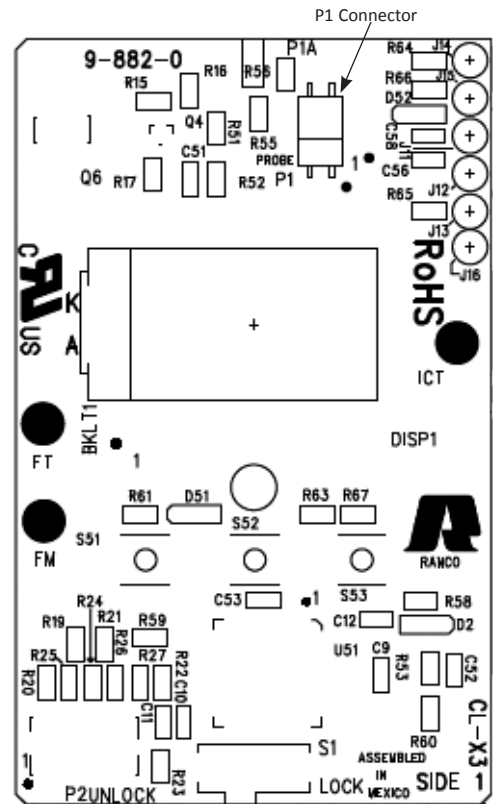

Figure 4

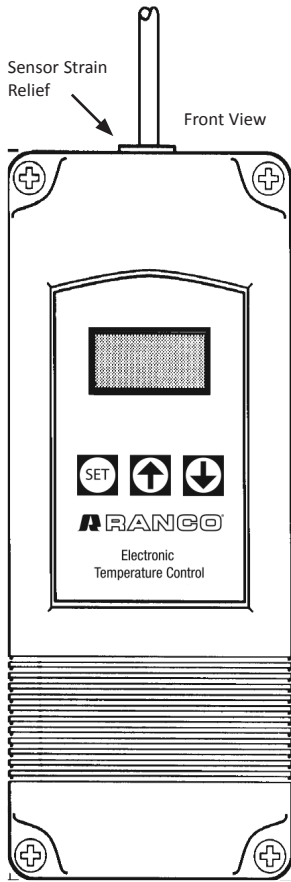

Figure 5

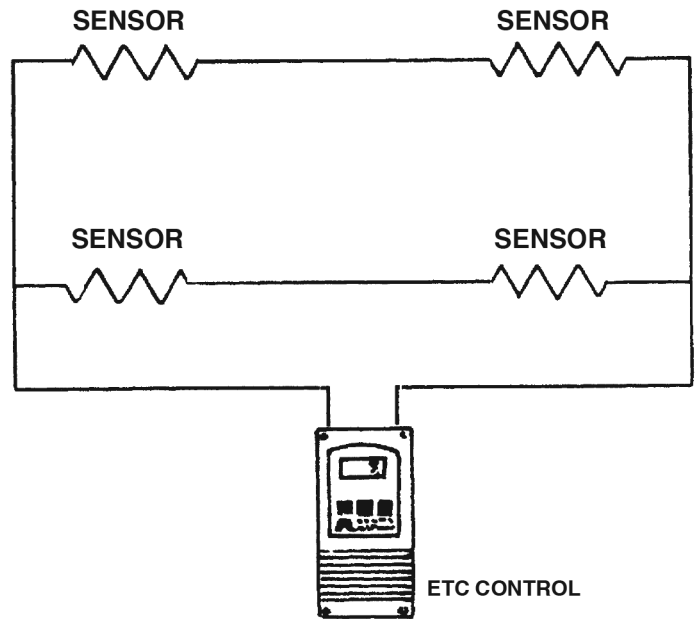

Figure 6  
Sensor wired in series/parallel for temperature averaging.



Customer Service Telephone 1.800.304.6563  
 Customer Service Facsimile 1.800.426.0804  
 HVACCustomerService@robertshaw.com

For Technical Service  
 Telephone 1.800.445.8299  
 TechnicalService@robertshaw.com

Robertshaw®, Ranco®, Paragon® and Uni-Line® are trademarks of Robertshaw, its subsidiaries and/or affiliated companies. All other brands mentioned may be the trademarks of their respective owners.

www.uni-line.com  
 www.robertshaw.com  
 ©2016 Robertshaw  
 04/16 – 352-00005-00 Rev C