

### DESCRIPTION/APPLICATION

The Ranco® C12-1800 and the O18-100 are used to control the ice bank size on beverage dispensers and other refrigeration systems which use an ice bank for thermal storage. The control bulb senses the ice bank by having a water-based fill which expands upon freezing and contracts upon thawing. This change in volume is transmitted by a hydraulic action through the capillary to operate the control switch.

Both the C12-1800 and the O18-100 (which has a NEMA 1 enclosure) have a single pole, single throw (SPST) switch. They may be used to directly control a single phase compressor; to control the pilot duty circuit of a contactor for single or three-phase compressors; or to control a pilot duty circuit for a liquid line solenoid valve.

### CONTROL OPERATION

(For both C12-1800 & O18-100)

The ice bank control is factory set and no field adjustments are to be made. It is designed to shut off the refrigeration system when the ice has built-up beyond the bulb by approximately 1/8 inch. The control switch will reclose when the ice has melted back, exposing a portion of the bulb.

#### 1st Cycle Effect

When the system is first put into operation, or returned to service, or after a prolonged off cycle, there will be a long running period to build the ice bank. During this first cycle, the ice bank may build approximately 1/4 inch larger than normal. However succeeding cycles will operate at the normal differential of approximately 1/8 inch of ice bank.

**CAUTION** To prevent possible electrical shock or equipment damage, disconnect electrical power to unit before and during installation. DO NOT restore electrical power to unit until the control is properly installed and grounded. DO NOT locate the control in an explosive atmosphere as a safety hazard can result due to possible spark generation in the control. Controls are not to be located in areas of splashing water or extreme moisture, dirt or dust, or in a corrosive or explosive atmosphere. These environments can shorten control life.

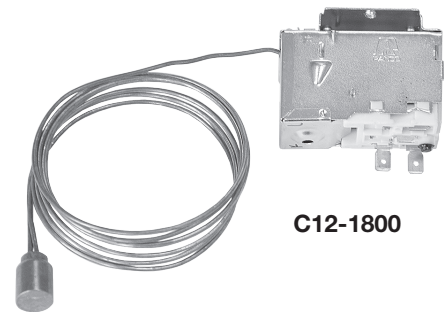

### CONTROL BODY MOUNTING

The C12 and O18 can be mounted in any position. Mount the control in a location that will permit proper capillary routing and bulb mounting (see following sections) and is away from moisture and splashing water. DO NOT twist or strain the control body as this may shift the calibration. Use only the mounting holes provided; no other holes are to be added to the control frame.

#### C12 only

The tips of the mounting screws must not extend through the mounting bracket so as to touch the control body. Make sure that the mounting surface is flat to prevent straining the control.

#### O18 only

Mount on an existing bracket, on the flat bracket provided, or surface-mount without a bracket. When attaching the control to a bracket use the 10-32 x 3/16 screws provided and the two tapped holes in the back of the control. **If other mounting screws are used, they must not enter the control more than 1/8 inch to avoid damage.** When surface mounting the control, use the .20 inch holes in the back of the control frame which can be accessed by removing the front cover. Make sure the surface is flat. Mounting to an uneven surface may cause improper control operation.

## CAPILLARY CARE AND MOUNTING

1. Hold the capillary close to the control and carefully uncoil the required amount. Minimize rebending which makes the capillary more susceptible to breakage.
2. DO NOT cut the capillary or bulb. Avoid sharp bends, kinks, strains or pinch marks in the capillary. Never allow the capillary to rest against sharp edges or rub against metal surfaces.
3. Provide a drip loop in the capillary to prevent moisture from reaching the control and causing an electrical short.
4. Don't immerse the excess capillary in the water bath or expose it to temperatures above 120°F. Avoid exposing the capillary to other extreme temperatures such as suction or discharge lines.
5. Secure excess capillary in 3 inch coils to avoid damage from vibration or contact with electrical terminals. Silicone adhesive applied between the coils will prevent rubbing.
6. Although securing the excess capillary is important to dampen vibration, it is just as important to allow enough slack so the capillary is not taut like a banjo string.
7. On startup of the equipment, observe the capillary for excessive vibration and make corrections as required.

## BULB MOUNTING

1. Locate the bulb where the maximum build up of ice is to be maintained since the entire bulb must be surrounded with ice to stop the refrigeration system.
2. A shorter cycle occurs when the bulb is located closer to the expansion device; a longer cycle results when the bulb is located closer to the outlet of the evaporator.
3. Using the strip clamp (when provided) or the original mounting, attach the bulb to the evaporator coil at least 3 inches below the water surface, away from a direct path of high velocity water. The distance that the bulb is mounted from the evaporator coils determines the ice bank thickness.

### TYPICAL BULB MOUNTING

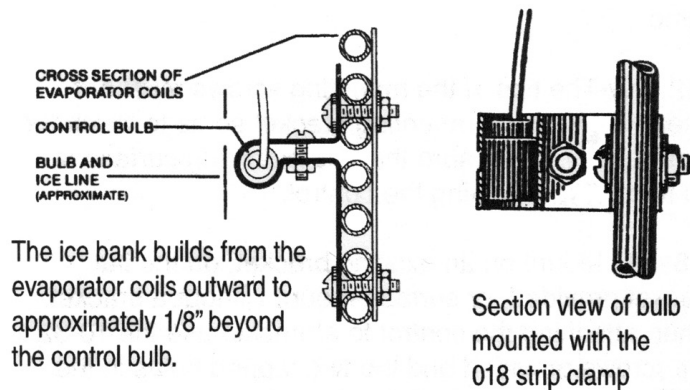

Figure 1 Using O18 Strip Clamp

## CONTROL WIRING

1. Disconnect electrical power to the unit.
2. All electrical wiring should conform to the National Electrical code and local regulations.
3. DO NOT exceed the listed electrical ratings.
4. Use copper conductors only.
5. Provide a drip loop in the wiring to prevent moisture from reaching the control.
6. The terminals must not be bent, cut off, drilled or retapped. Electrical leads should not be taut; allow slack for temperature change and vibration.

When mounting a conduit connector to the O18 control frame, take care to not damage the switch or the control mechanism.

The cup washers furnished with the O18 are to be used when the conductor wires are directly connected to the terminals. The stripped end of the conductor should be made into a clockwise formed eye with an inside diameter to slip over the shank of the terminal screw. The clockwise forming will tend to wrap the eye of the conductor around the screw shank as it is being tightened. The cup washer, with its flanges outward, should be placed between the terminal and the screw head to capture the eye of the conductor.



Figure 2 O18 Electrical Terminals

## ELECTRICAL RATINGS

	VAC	FLA	LRA	PD VA	HP
C12-1800	240	20	85	720	
	277	16	60	720	
O18-100	120	17	102	720	
	240	17	102	720	3
	241/600	—	—	125	
	Hermetic Compressor Motor				
	240	20	80		

## CHECKOUT

Inspect work to be assured that all the above steps were taken. Start up the unit and arrange to observe at least one full cycle.

## ALTITUDE ADJUSTMENT

The ice bank control is not affected by altitude.



Customer Service Telephone 1.800.304.6563  
Customer Service Facsimile 1.800.426.0804  
HVACCustomerService@robertshaw.com

For Technical Service  
Telephone 1.800.445.8299  
Facsimile 1.630.260.7294  
TechnicalService@robertshaw.com

Robertshaw®, Ranco®, Paragon® and Uni-Line® are trademarks of Robertshaw, its subsidiaries and/or affiliated companies. All other brands mentioned may be the trademarks of their respective owners.

www.uni-line.com  
www.robertshaw.com  
©2015 Robertshaw  
3/15 –153108 Rev C