

Installation Guide 720-079 Universal Electronic Ignition Gas Valve Uni-Kit®

INTERMITTENT PILOT • HOT SURFACE • DIRECT SPARK

The Robertshaw® 720-079 Universal Electronic Ignition Gas Valve Uni-Kit® is designed to work equally well on Intermittent Pilot, Direct spark and Hot Surface applications.

The 720-079 features a manual selector, wiring connections and adjustments that are all easily accessible on the top of the valve. The 720-079 Uni-Kit has a pressure regulator that is pre-set at 3.5" W.C. for natural gas. For L.P. gas applications the valve can be converted by using a pressure regulator conversion kit that is included.

The 720-079 incorporates a manual valve, pilot valve (dual automatic valves and a main gas pressure regulator all in a small compact valve with a swing radius of 3-9/16". The small size of the 720-079 lends itself to replacing many O.E.M. and competitive valves. The 720-079 is multi-positional and can be mounted in any position, except upside down.

APPLICATION LIMITATIONS

Do not use on direct spark or hot surface applications if original valve was a "slow opening" type. Also 720-079 will not replace Robertshaw 7000K series or White-Rodgers "cycle pilot" gas valves.

SPECIFICATIONS

| | |
|------------------------|--|
| Electrical Ratings | 24 VAC, .45 amps |
| Pressure Regulator | |
| Natural Gas | factory set at 3.5" W.C. |
| L.P. gas | factory set at 11.0" W.C. |
| Ambient Temperature | -40° to 175°F |
| Maximum Inlet Pressure | 7" W.C. - natural gas 14" W.C. - L.P. gas |

REGULATION CAPACITIES

| SIZE | TYPE GAS | | | |
|-------------|----------|---------|--------|---------|
| | NATURAL | | L.P. | |
| | MIN. | MAX. | MIN. | MAX. |
| 3/8" x 3/8" | 15,000 | 175,000 | 15,000 | 280,000 |
| 1/2" x 3/8" | 15,000 | 175,000 | 15,000 | 280,000 |
| 1/2" x 1/2" | 15,000 | 200,000 | 15,000 | 320,000 |
| 1/2" x 3/4" | 15,000 | 200,000 | 15,000 | 320,000 |
| 3/4" x 3/4" | 15,000 | 200,000 | 15,000 | 320,000 |

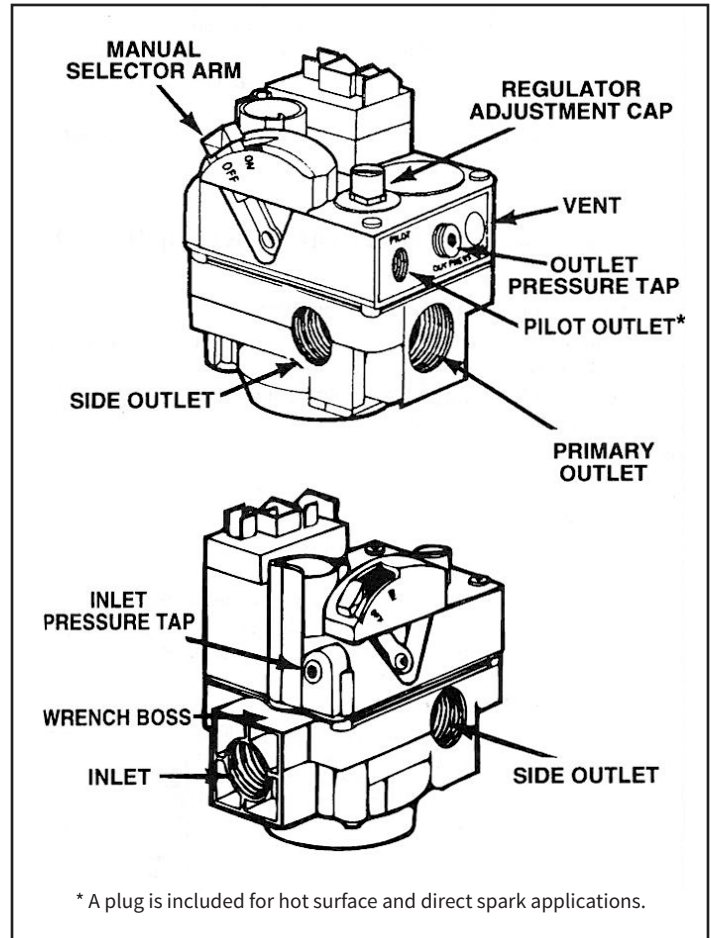

NOTE:

To prevent unsafe attempts at repair, special screws are used and replacement parts are **NOT** available.

INSTALLATION INSTRUCTIONS - ALL APPLICATIONS

Turn off gas supply and electrical power to equipment before servicing.



CAUTION
THIS DEVICE SHOULD BE INSTALLED BY A QUALIFIED TECHNICIAN WITH DUE REGARD FOR SAFETY AS IMPROPER INSTALLATION COULD RESULT IN A HAZARDOUS CONDITION.

PIPING

1. Check replacement valve for multiple outlets (side outlets). If it has them, be sure all unused outlets are plugged using the socket plugs provided.
2. Pipe or tubing must be clean and free of scale and dirt.
3. Make sure gas piping is pressure tested before control is connected. High pressure can damage control causing a hazardous condition. Do not subject control to more than 1/2 PSI, (14" W.C.) inlet pressure.

4. If it's not already installed, a drip leg (sediment trap) must be added to the gas supply line to the control. (See figure below.) All piping must comply with local codes and ordinances and with National Fuel Gas Code (ANSI Z223.1/ NFPA, No. 54).

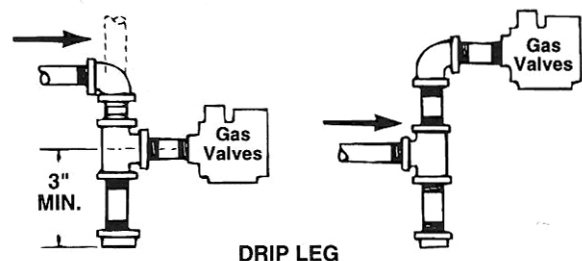

INSTALLATION INSTRUCTIONS (Cont'd)

- Using pipe thread compound suitable for the gas being used, apply a small amount on the male pipe threads. (Do not use Teflon tape or Teflon compound.) Leave the first two threads clean. Never use compound on female threads as it might be pushed into the control body.
- The gas valve is multi-positional and can be mounted in any position (except upside down) without affecting its operation.
- Install gas valve so gas flow conforms with the inlet and outlet of the control.
- DO NOT** insert any object other than suitable pipe or tubing in the inlet or outlet of this control. Internal damage may occur and result in a hazardous condition. A backup wrench should only be used on the wrench boss provided for this purpose (see drawing), never on the body of the control, as this could distort the casting.

NOTE: Do not over tighten any pipe connections, as this could crack the valve body. A valve with a cracked valve body will not be warranted.

PRESSURE REGULATOR VENT

The 720-079 has a built-in Vent Limiter. The regulator vent is tapped 1/8" tubing if vent tubing is required. **CAUTION:** If bleed tubing is used, do not allow main burner or pilot flame impingement on the tubing as this will eventually cause clogging of the tubing and improper regulator operation. If bleed tubing is not used, the regulator vent must be properly shielded from moisture.

LEAK TEST

Leak test with a soap solution after installing with main burner on. Coat pipe and tubing joints, gasket, etc. with soap solution. Bubbles indicate leaks.

INSTALLATION INSTRUCTIONS - INTERMITTENT PILOT

PILOT TUBING

- Make sure tubing is free of burrs and dirt.
- We strongly recommend that the pilot orifice be checked and cleaned if necessary at this time.
- Connect pilot tubing into the control using fitting provided, and tighten for a gas tight seal.

WIRING

DO NOT short gas valve terminals. This will damage wall thermostat and void warranty.

- Check the system for the proper transformer by comparing the VA ratings of the transformer and the system. The system rating is determined by multiplying the voltage draw times the amp draw. Normally 20VA

transformers are sufficient for heating only applications and 40VA for heating/cooling applications.

NOTE: Improper transformer VA rating will cause erratic system operation.

- Connect the wire from the "MV" terminal on the ignition control unit to the "M" terminal on the gas valve.
- Connect the wire from the "PV" terminal on the ignition control unit to the "P" terminal on the gas valve.
- Connect the wire from the "MV/PV" terminal on the ignition control unit to the "C" terminal on the gas valve.

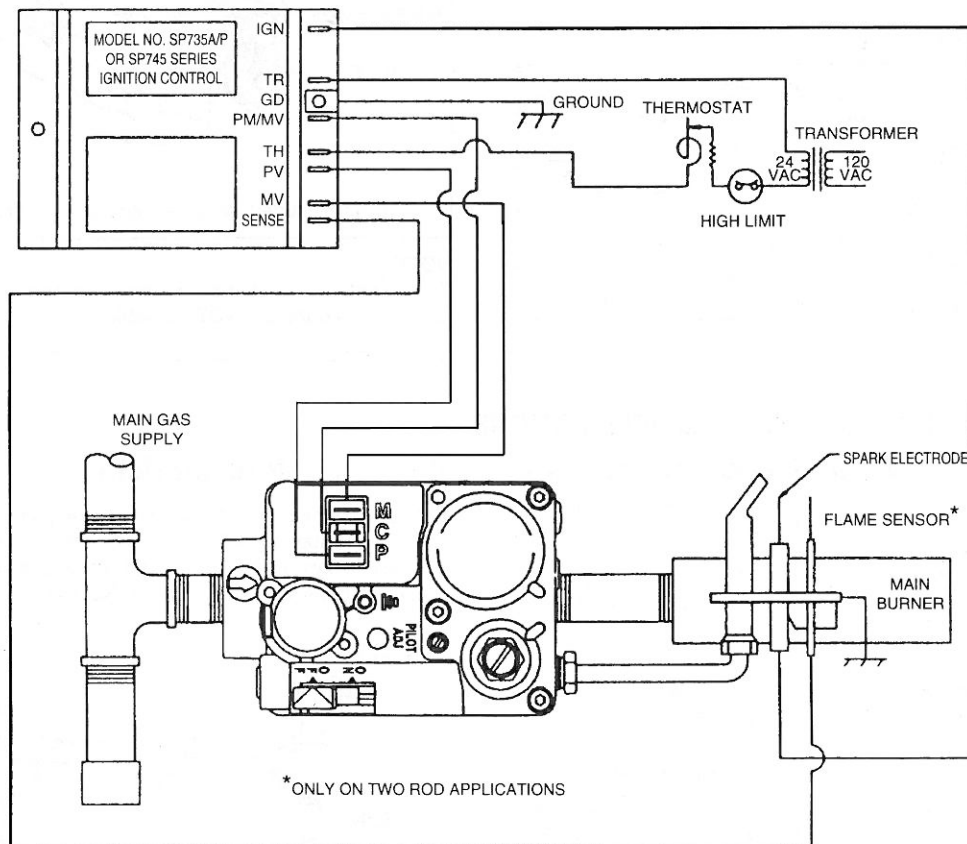

TYPICAL ROBERTSHAW INTERMITTENT PILOT APPLICATION

INSTALLATION INSTRUCTIONS – HOT SURFACE APPLICATIONS

PILOT TUBING

NOTE: Some hot surface applications use the pilot outlet, if so proceed as directed below. If not used install pilot outlet tubing plug packaged in the 720-079 gas valve kit then proceed to “wiring”.

1. Make sure tubing is free of burrs and dirt.
2. We strongly recommend that the pilot orifice be checked and cleaned if necessary at this time.
3. Connect pilot tubing into the control using fitting provided, and tighten for a gas-tight seal.

WIRING

DO NOT short gas valve terminals. This will damage wall thermostat and void warranty.

1. Check the system for the proper transformer by comparing the VA ratings of the transformer and the system. The system rating is determined by multiplying the voltage draw times the amp draw.

Normally 20VA transformers are sufficient for heating only applications and 40VA for heating /cooling applications.

NOTE: Improper transformer VA rating will cause erratic system operation.

2. Locate the white wire terminal adaptor (jumper) that is included with the 720-079 gas valve.
3. Connect the white wire terminal adaptor to the “M” and “P” terminals on the 720-079 gas valve.
4. Determine which wire was connected to the “main valve” terminal on the original valve. Connect this wire to the remaining terminal on the white wire terminal adaptor.

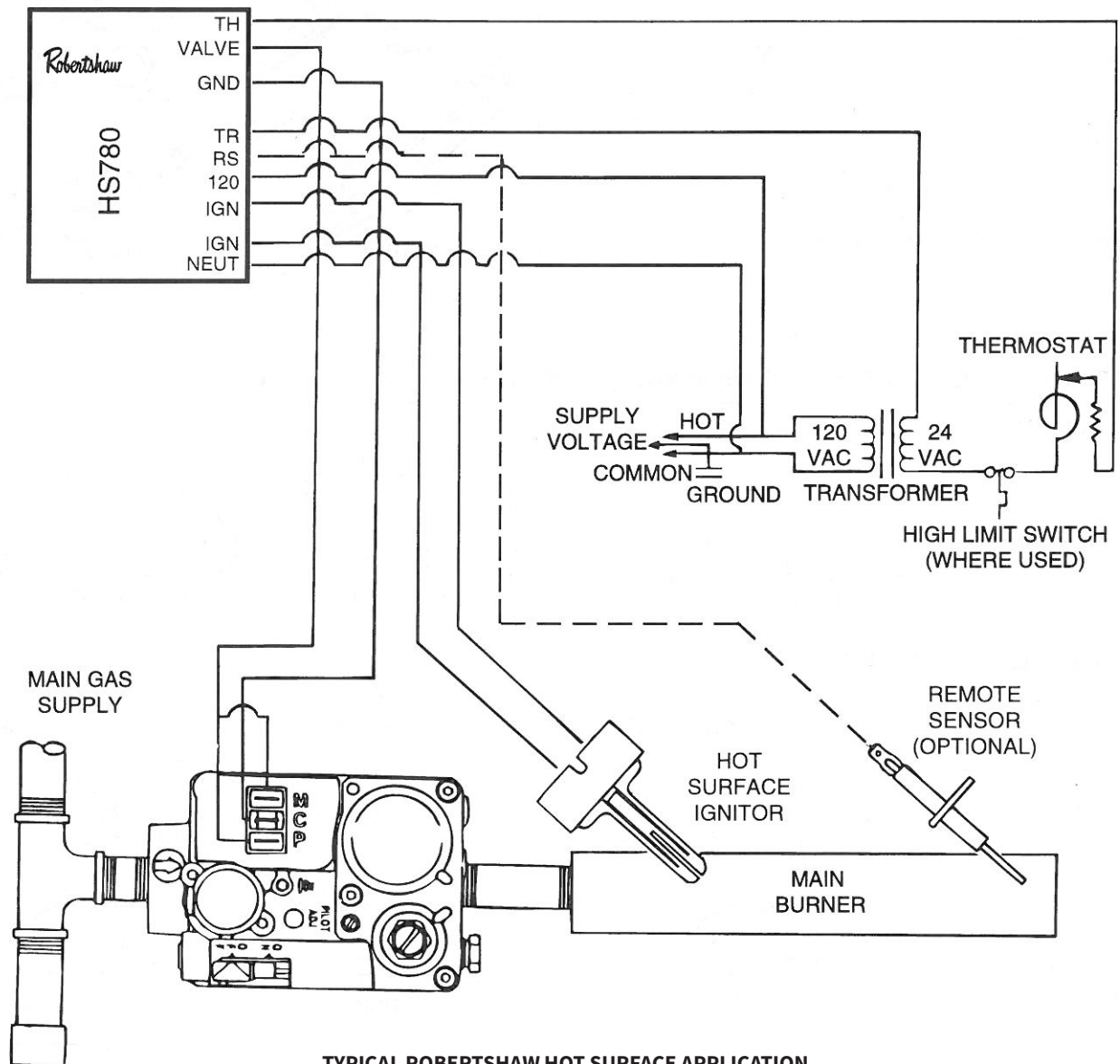

TYPICAL ROBERTSHAW HOT SURFACE APPLICATION

INSTALLATION INSTRUCTIONS - DIRECT SPARK

PILOT OUTLET

Install the pilot tubing plug packaged in the 720-079 gas valve.

WIRING

DO NOT short gas valve terminals. This will damage wall thermostat and void warranty.

1. Check the system for the proper transformer by comparing the VA ratings of the transformer and the system. The system rating is determined by multiplying the voltage draw times the amp draw. Normally 20VA transformers are sufficient for heating only applications and 40VA for heating/cooling applications.

NOTE: Improper transformer VA rating will cause erratic system operation.

2. Locate the white wire terminal adaptor (jumper) that is included with the 720-079 gas valve.

3. Connect the white wire terminal adaptor to the "M" and "P" terminals on the 720-079 gas valve.
4. Determine which wire was connected to the "main valve" terminal on the original valve. Connect this wire to the remaining terminal on the white wire terminal adaptor.
5. Connect the remaining wire from the original gas valve to the "C" terminal on the 720-079 gas valve

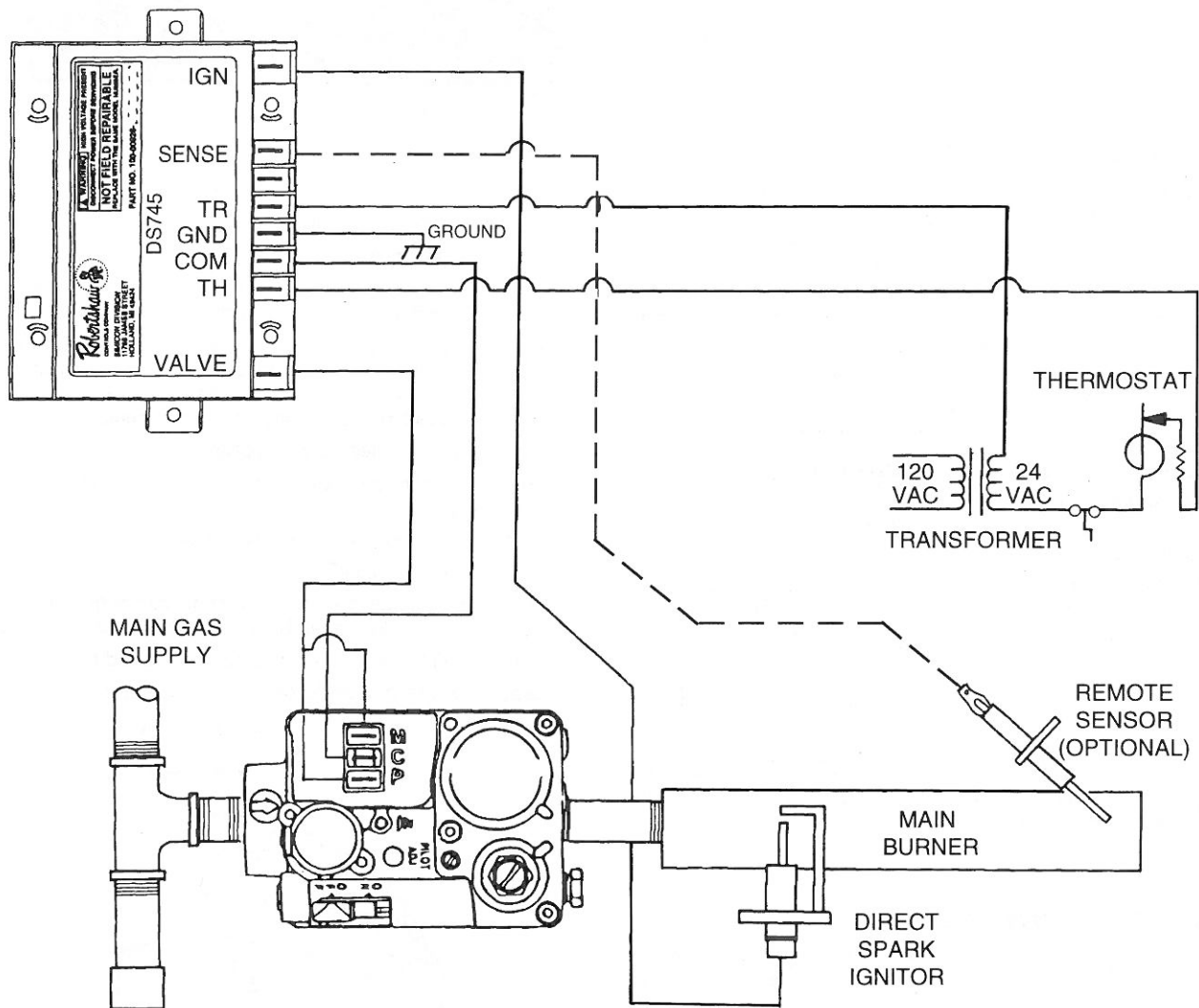

TYPICAL ROBERTSHAW DIRECT SPARK APPLICATION

OPERATING INSTRUCTIONS



CAUTION

- WARNING:** If you do not follow these instructions exactly, a fire or explosion may result with property damage, personal injury or loss of life.
- Smell all around the appliance area for gas. If the appliance uses L.P. (bottled) gas, also be sure to smell next to the floor because L.P. gas is heavier than air.
- WARNING:** If you smell gas, immediately shut off the manual valve in the gas piping to the appliance. Don't touch any electrical switch or use the phone. Leave the building and call your gas supplier. If he cannot be reached, call the fire department.
- WARNING:** Do not force the gas control knob on the appliance. Use only your hand to push down and/or to turn the gas control knob. Never use any tools. If the gas control knob will not operate by hand, the control should be replaced by a qualified service technician. Force or attempted repair may result in fire or explosion.
- WARNING:** The gas control must be replaced if it has been exposed to water.

SERVICE INSTRUCTIONS

CAUTION: If control has been exposed to water in any way, it must be replaced. If gas valve fails to shut off, do not turn off electrical power. Turn off gas supply allowing fan or circulating pump (if so equipped) to continue running until system has cooled. Replace control.



WARNING

Servicing of gas controls, appliance and systems must be performed by qualified service personnel only.

PRESSURE REGULATOR ADJUSTMENTS

Adjustment of the pressure regulator is not normally necessary since it is preset at the factory. However, field adjustment may be accomplished as follows:

NOTE: Manometer attachment may be accomplished at pressure tap plug, above control outlet, as shown in figure to the right. If using inlet pressure tap to measure incoming pressure. See drawing on first page.

- Manometer or gauge attachment may be accomplished at pressure tap plug (D).
- Remove regulator adjustment screw cap (top of control - A).
- With small screwdriver, rotate adjustment screw (B) "clockwise" to increase, or "counterclockwise" to decrease pressure to comply with manufacturer's specifications.
- Replace regulator adjustment screw cap (A).

REGULATOR CONVERSION

CAUTION: Main burner and pilot orifices must be changed when regulator is converted from one type of gas to another.

- Turn off gas and electricity to appliance.
- Remove slotted cap (A), adjusting screw (B), and natural gas spring - not color coded - (C), from control.
- Install new L.P. spring - color coded with a black strip.
- Install new adjusting screw (B).
- Attach manometer or pressure gauge at the outlet pressure tap. (D)

- Turn wall thermostat to its lowest setting. Remove burner access panel(s).

Selector arm must only be operated by hand (see below). **DO NOT** use pliers, wrenches or other tools to operate the arm. The selector arm cannot be moved into the "Off" position without first depressing the lever to the "On" position.

- Move selector arm to the "Off" position. (See figure 1.)
- WARNING:** Wait at least 5 minutes to allow any gas in the combustion chamber to vent. If you then smell gas in the appliance area or near the floor, STOP and follow warning instructions to the left. Failure to do so may result in fire or explosion.
- Move selector arm to the "On" position, (see figure 2), and set room thermostat to desired temperature. Allow burner to cycle on and off.
- Leak test with a soap solution after installing with main burner on. Coat pipe and tubing joints, gasket, etc. with soap solution. Bubbles indicate leaks.
- Replace burner access panel.

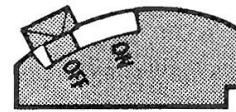

FIGURE 1

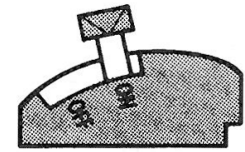
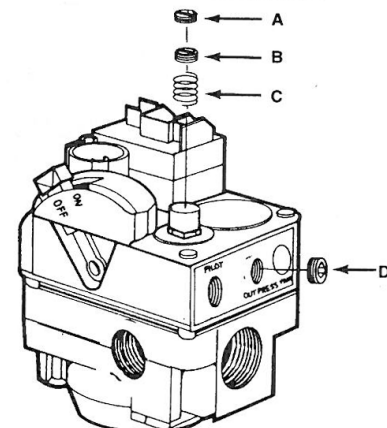

FIGURE 2

- Turn gas and electricity on.
- Turn room thermostat to call for heat.
- With burner on, adjust screw (B) to supply LP. gas to pressure as recommended by the appliance manufacturer.
- If adjusting screw (B) reaches its maximum depth (bottoms out) before recommended pressure setting is reached, turn screw counterclockwise until pressure drops slightly (approximately 0.1" W.C.) **WARNING:** Do not stretch or alter spring.
- Turn off gas and electricity to appliance.
- Remove manometer or pressure gauge and reinstall pressure tap outlet plug (D).
- Install new red slotted cap in place of (A).
- Turn gas and electricity on.
- With burner operating, immediately check all fittings for leaks with soap solution. Bubbles indicate leaks that must be corrected.
- Attach label to show control has been converted to L.P.
- Set room thermostat to desired temperature.





RANCO • PARAGON • CASTFUTURA

Customer Service
+1 800 304 6563
HVACCustomerService@robertshaw.com

Technical Service
+1 800 445 8299
TechnicalService@robertshaw.com

www.robertshaw.com
©2024 Robertshaw
11/24 – 1-870 Rev D