

PS2110 – 1 Heat / 1 Cool

PS2210 – Multi-Stage 2 Heat / 1 Cool

Features and Benefits

Multi-Stage 2 Heat / 1 Cool – PS2210 only

Operates on both multi-stage gas/electric furnaces and heat pumps to reduce inventory needed

Bigger Brighter Backlight

Makes viewing and setting the temperature easier

Adjustable Temperature Differential

Maintains optimal customer comfort

Worry-Free Memory Retention – PS2210 only

Maintains setpoint and programmed parameters, even during power outages

Filter Monitor

Provides notice when filters need changing

Low Temperature Freeze Protection – PS2110 only

Turns on heat automatically when temperature goes below 37°F (3°C) and protects pipes from freezing

Automatic Compressor Short Cycle Protection

Reduces wear and tear of HVAC equipment with this system safeguard

O and B Terminals

Provides greater system flexibility

Zone System Compatible

Acts as a sensor within the system

Quick Wire Terminal Block

Uses sturdy wire clamps – no wrap-around of screws for fast and easy installation

Affordable Comfort Control

The PerfectSense™ PS2000 thermostat series is the perfect choice when it comes to non-programmable temperature control.

With the comfort, convenience, and efficiency features that homeowners and contractors want, the PS2000 series provides value-packed thermostats for an economical price.

- Bigger brighter backlight makes it easy to read any time of the day.
- A fully adjustable temperature differential provides increased comfort control.
- The front load battery door makes it simple to replace the batteries.

All PS2000 thermostats are fully compatible with all standard 24V AC heating and cooling systems. Additional compatibility with multi-stage and heat pump systems are available in the PS2210 model.

Add in easy installation, expert technical service, and quality you can depend on, the PerfectSense™ PS2000 thermostat series is the perfect choice in temperature control.

An ISO 9001 – 2008 Certified Company

2 Year
Limited
Warranty



Terminal Designations

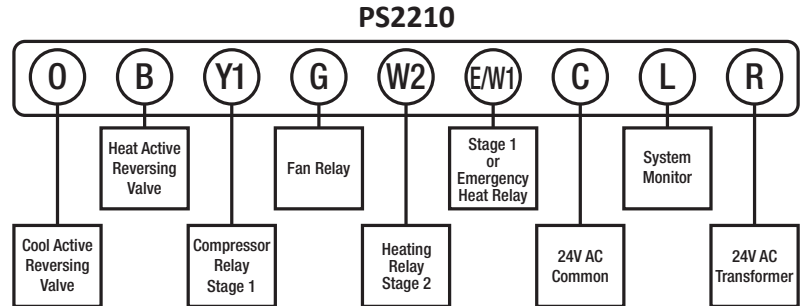
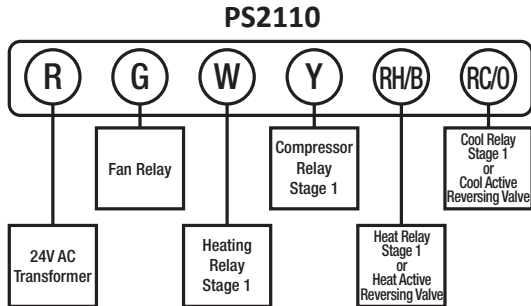

Technical Specifications

Product Weight	11.2 oz. (320 grams)
Electrical Rating	24V AC (18-30V AC) 1 Amp maximum load per terminal 3 Amp total maximum load (all terminals combined)
Temp. Control Range	45°F to 95°F (7°C to 35°C)
Accuracy	± 1°F (± 0.5°C)
Power	PS2110 – 3.0V DC (2 AA alkaline batteries included) PS2210 – 24V AC with battery back-up (2 AA alkaline batteries included)
System Configurations	PS2110 – Single stage electric, gas, oil or millivolt heating or heating/cooling systems including single stage heat pump systems PS2210 – Multi-stage electric, gas or oil heating or heating/cooling systems including multi-stage heat pump systems
Terminations	PS2110 – R, G, W, Y, RH/B, RC/O PS2210 – O, B, Y1, G, W2, E/W1, C, L, R

Replacement Chart

PS2110	
Robertshaw*	8400, 8401, RS2110
Braeburn*	1000, 1010, 1005NC, 1000TL, 1000NC
Lux	DMH110
Honeywell	TH1110D, TH8775C
White-Rodgers	1F78-144, 1F86-344
PS2210	
Robertshaw*	8425, RS2210
Braeburn*	1100, 1210, 1200NC
Lux	DMP2110
Honeywell	TH1210D, T8411R, TH3210D
White-Rodgers	1F72-174

*Verify specific application requirements before substitution.

Shipping Specifications

Individual Carton Dimensions	8" x 1.4" x 4.5" (20cm x 3.5cm x 11.5cm)
Master Carton Quantity	6
Master Carton Dimensions	8.46" x 8.07" x 5.71" (21.5cm x 17.7cm x 14.5cm)
Master Carton Weight	4.4 lbs. (2kgs.)

UNI-LINE®

Customer Service Telephone 1.800.304.6563
Customer Service Facsimile 1.800.426.0804
HVACCustomerService@robertshaw.com
Customer Service Europe Telephone
00 800 77 47 74 77

For Technical Service
Telephone 1.800.445.8299
TechnicalService@robertshaw.com

Robertshaw®, Uni-Line® and PerfectSense™ are trademarks of Robertshaw, its subsidiaries and/or affiliated companies. All other brands mentioned may be the trademarks of their respective owners.

www.uni-line.com
www.robertshaw.com
©2015 Robertshaw
10/15 – 150-2544 Rev B